

MINI CHECK PLUS



Main features

- Cadences up to 35 ppm.
- Capacity: 3 kg - 1 g with motorized belt width 185 mm.
- Capacity: 6 kg - 2 g / 15 kg - 5 g with motorized belt width 400 mm.
- 1 motorized belt, closed loop.
- Brushless motor and drive board, speed up to 40 m/min.
- Working temperature: from 0 °C to + 40 °C.
- Power supply: 230 Vac (Hz 50/60).
- Maximum power: 300 W.
- Resistive PC/Panel 12" display, suitable for use with gloves and in the presence of water/condensation.
- Structure and carpentry in aluminum and stainless steel.
- Belt height from the ground: 850 +/- 50 mm.
- Machine management by PLC.
- Expulsion management output.
- Led light column out of tolerance.

Software

- Weight control program.

Selectable functions

- External availability for data sharing.
- Weighing range selection with reject output enabling.
- Viewing reports on checks performed.
- Export production report on USB port.
- Multilingual selection.
- Multi-level password.

PLU

- PLU number: 9999.
- For each PLU:
 - 2 description fields.
 - Tare.
 - Minimum threshold.
 - Maximum threshold.
 - Duration and delay expulsion.
 - Alarm upon reaching number of expulsions.
- Automatic programming of parameter (motor speed, minimum and maximum weighing threshold, duration and delay expulsion).

Totals

- Totals per PLU.
- Totals per lot of traceability, lot/PLU.

I/O Section

- 1 USB 2.0.
- 1 Ethernet.
- 2 Electrical signals (clean contacts).

Diagnostics

- Continuous monitoring of the status of the machine and of all integrated systems.

Options

- Network machine management software with RS server communication protocol.
- 2D camera for presence and reading of the label.
- 2D camera for QR Code reading.
- Cameras for optical control.
- External PROFIBUS interface, Profibus protocol with PCB.
- Communication protocol ETHERCAT.
- Piston ejector, arm or pneumatic blow.
- Tilting ejector.
- Tilting basket.
- Overflow photocell.
- Conveyor belts for ejectors.

Dimensions

Model MINI CHECK Plus **useful belt dimensions [mm]**

WEIGHING
185x510

Model MINI CHECK Plus **useful belt dimensions [mm]**

WEIGHING
400x630

Layout

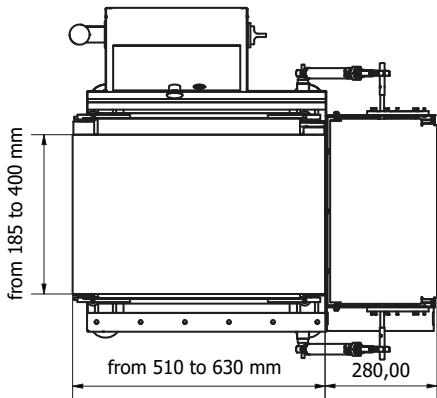
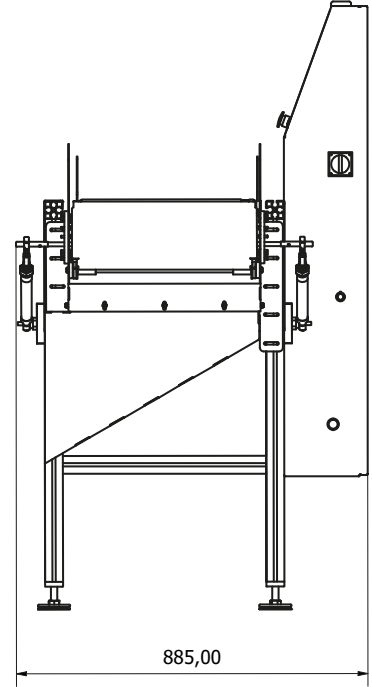
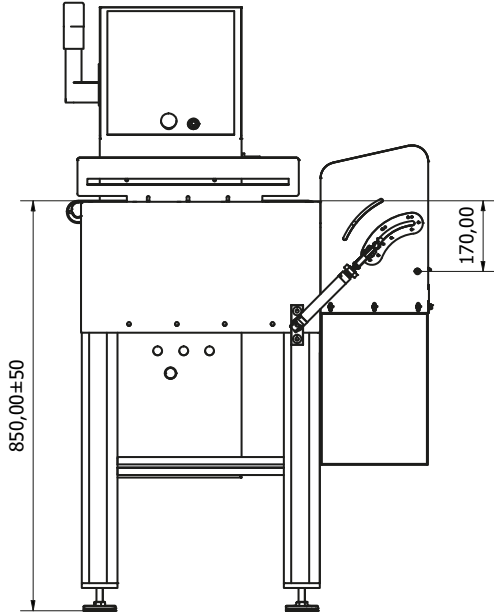

MINI CHECK PLUS

MID APPROVAL

MODULAR AND INTEGRABLE

REDUCED MAINTENANCE COSTS

SELF-DIAGNOSTIC

CONNECTIVITY AND DATA SHARING WITH OTHER SOFTWARE

REMOTE ASSISTANCE



 TECHNOLOGY for Your Business

R.S. Bilance S.r.l.
Via Dionisio 26/A - 95030 Mascalucia - (CT) Italia
Tel. +39 095 910806
commerciale@rsbilance.com
www.rsbilance.com

