

# AL500

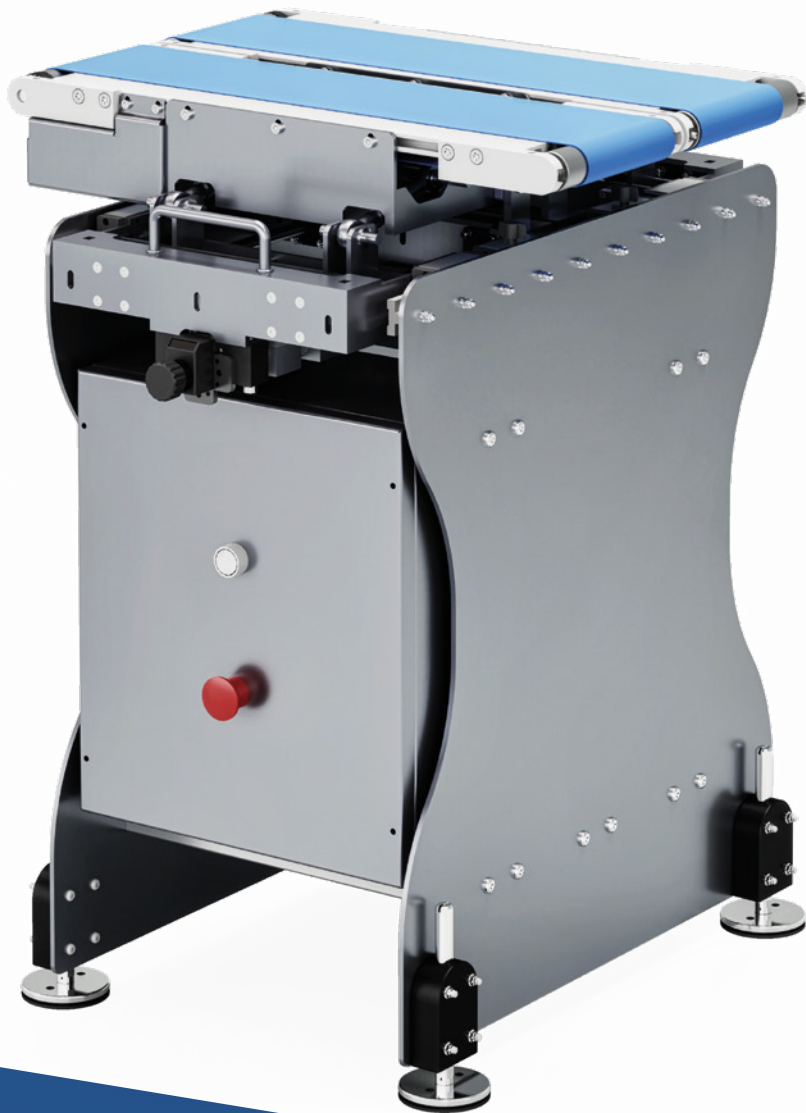

# AL500

Light signal, aligner

## Main features

- Cadences up to 120 ppm.
- 2 motorized belts closed loop, width 230, 275 and 320 mm.
- 2 brushless motors and drive boards, speed up to 70 m/min.
- Working temperature: from 0 °C to + 40 °C.
- Power supply: 230 Vac (Hz 50/60).
- Maximum power: 1 kW.
- Structure and carpentry in aluminum and stainless steel.
- Machine management by PLC.
- Electrical panel with mushroom and reset.

## Layout

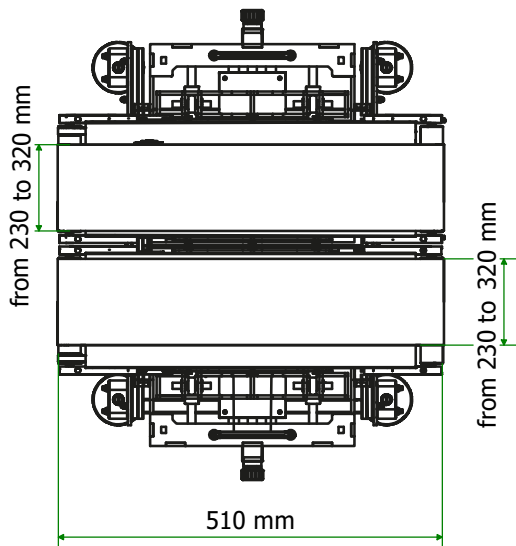
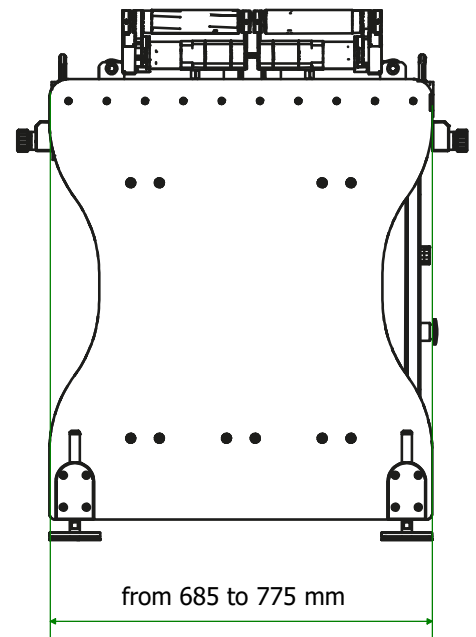
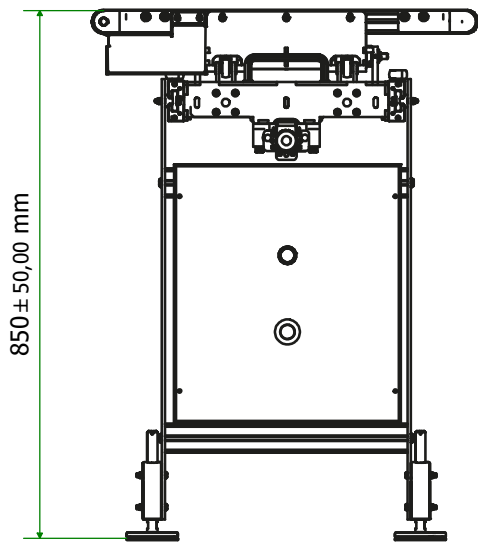

Technical specifications and images may be subject to improvements and modifications without notice.

# AL500

**MODULAR AND INTEGRABLE**

**REDUCED MAINTENANCE COSTS**

**SELF-DIAGNOSTIC**

**CONNECTIVITY AND DATA SHARING WITH OTHER SOFTWARE**

**REMOTE ASSISTANCE**



 TECHNOLOGY for Your Business

R.S. Bilance S.r.l.  
Via Rinaudo, 19, Valcorrente - 95032 Belpasso CT  
Tel. +39 095 3523283  
commerciale@rsbilance.com  
www.rsbilance.com

